

DAB field trials in Finland

V. Erkkilä

M. Jokisalo

(Yleisradio Oy)

1. Introduction

The Finnish Broadcasting Company, working in collaboration with the Nokia company, has begun field trials with 3rd generation Digital Audio Broadcasting equipment.

Two transmitters have been installed and a measuring vehicle and demonstration bus have been equipped. The first transmitter has been in service since February 1994 and the second one since August. Extensive measurements began in September 1994, and the present article gives some preliminary indications of the results achieved.

In contrast to most of the other field trials that have been done with DAB systems, the Finnish project is investigating reception in Band II (105 MHz).

2. Transmitter network

The locations of the two transmitters are shown in *Fig. 1*. The main site is Espoo, where a DAB transmitter has been installed feeding the same antennas as the VHF/FM transmissions. The antenna is horizontally polarized and the radiation pattern is omnidirectional. The e.r.p. is 2.5 kW and the effective antenna height is 280 m.

Original language: English
Manuscript received 27/10/1994

The DAB logo has been registered by a member of the Eureka 147 – DAB consortium.

The article describes the facilities recently installed for DAB field trials in VHF Band II, in Finland.

Preliminary results are given, together with some indications of specific aspects of DAB reception which will require more-detailed investigation.

A full-scale measurement campaign is due to begin in autumn 1994.

The antenna at Sipoo has a directional radiation pattern with a 3 dB beamwidth of about 60°. It has both vertical and horizontal elements and can transmit in either polarization. The e.r.p. is 600 W and the effective antenna height is about 80 m.

The transmitters are fed by analogue microwave television links from the tower at the Finnish Broadcasting Company's main building in Pasila. The delay between the modulations at each transmitter, the transmitter powers and the polarization (Sipoo only) can be controlled from Pasila.

Fig. 2 shows a block diagram of the transmitting equipment. A 36-MHz COFDM signal is generated using test equipment supplied by the Philips company. This signal is down-converted to 3 MHz and distributed to the transmitters via the television link equipment. The signals can be attenuated and delayed before distribution. To main-

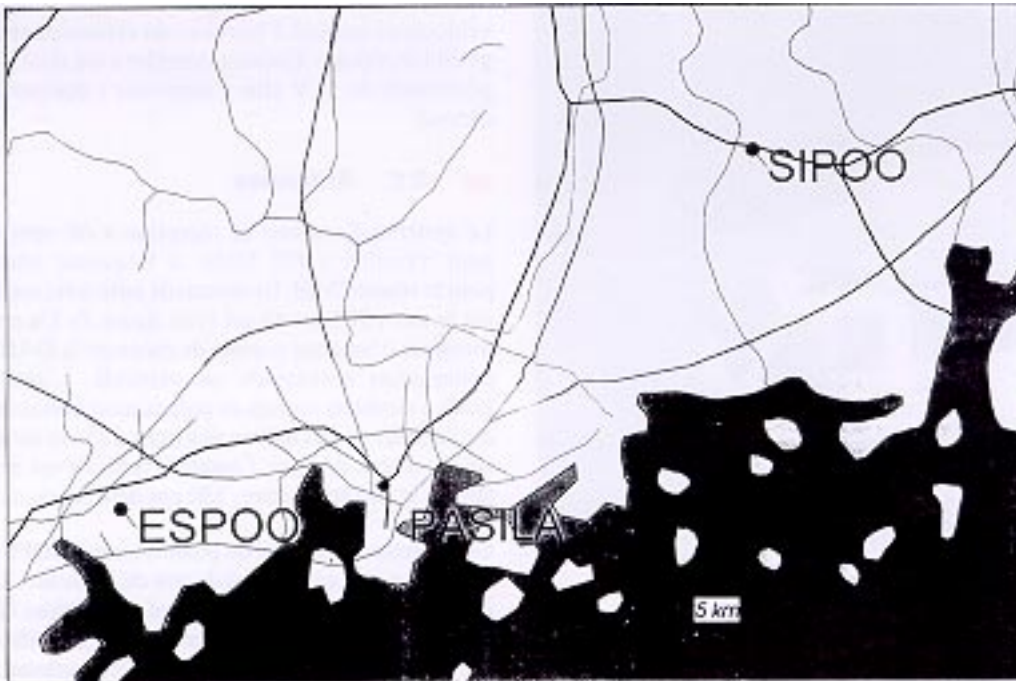

◀ Figure 1
Locations of the DAB
test transmitters in
the Helsinki area.

Figure 2
Block diagram of the
transmission network
equipment.
▼

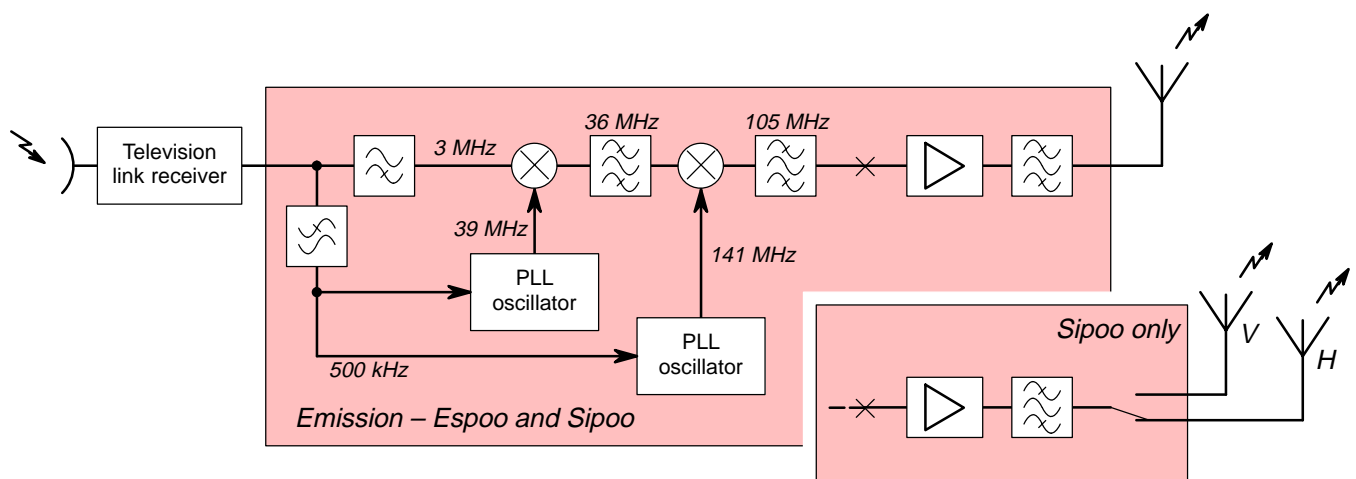
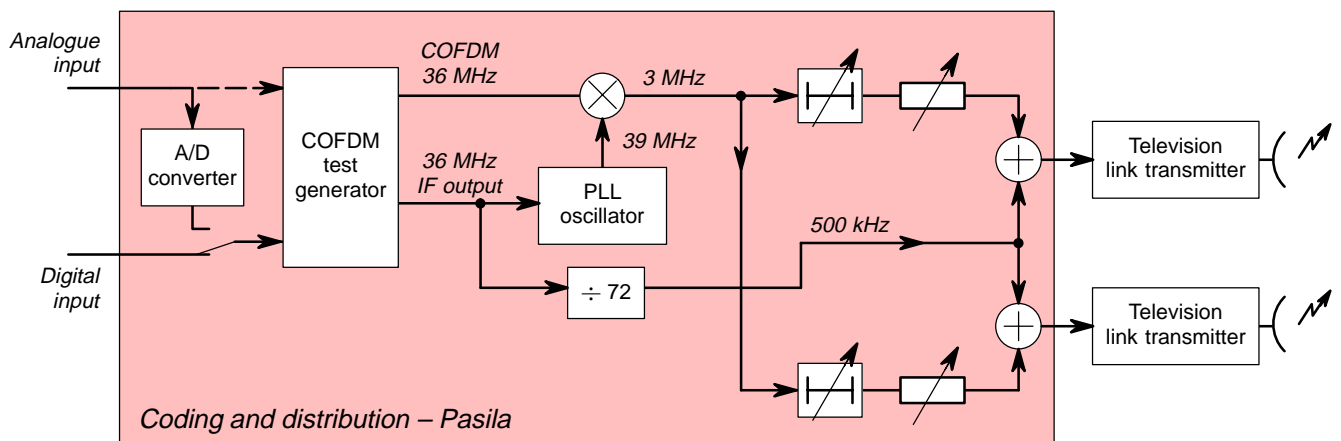



Figure 3 ▲
DAB measurement van
with vertical and
horizontally-polarized
antennas on the ground
plane.



Figure 4 ►
GPS antennas.

Photos:
Pekka Kuparinen

tain the frequency stability needed for single frequency network (SFN) operation, a 500-kHz reference signal is distributed with the DAB signal. At the transmitting stations, this is used as a reference for phase-locked loop (PLL) oscillators used for the up-conversion of the DAB signal from 3 MHz to 105 MHz.

The output power from the power amplifiers is 200 W with about 7 dB back-off. The intermodulation

products are at a level of -40 dB. After the amplifier, the signal is filtered with a six-cavity filter.

3. Measuring vehicle

A Volkswagen van has been equipped as a measuring vehicle. The interior of the van has been converted into a complete travelling laboratory and an extra 12 V generator has been fitted to provide power for the test equipment.

3.1. Antennas

The receiving antenna system has been optimized for operation at 105 MHz, the frequency chosen for the DAB network. A ground plane has been mounted on the roof at a height of 203 cm from the ground (see Fig. 3). An antenna switch permits DAB reception in either horizontal or vertical polarization. The horizontally-polarized crossed-dipole DAB antenna is fitted on a plastic mast, 125 cm above the ground plane and the vertical one is mounted on the ground plane, 130 cm behind the mast.

A Global Positioning System (GPS) antenna is mounted on the front corner of the van roof. An active antenna for the differential GPS signal (285 kHz) is fitted at the top of the mast, to minimise its influence on the vertical DAB receiving antenna (Fig. 4).

The polar patterns of the antennas were measured by turning the van on a rotating platform some 200 m from a test generator antenna. The horizontal polar pattern of the horizontal antenna is circular to within ± 1 dB; for the vertical antenna it is circular to within ± 2.5 dB (Fig. 5). The cross-polar discrimination of the horizontal antenna was measured as being always better than 8 dB (average 16.1 dB) and for the vertical antenna it was better than 5.5 dB (average 11.7 dB).

3.2. Measurement equipment

A block diagram of the measurement facilities installed in the van is shown in Fig. 6. The measurement system is controlled by a Personal Computer (486, 33 MHz). A special trigger system has been designed to ensure the correct timing of successive field-strength measurements and to control the DAB antenna switch. To prevent field-strength measurements coinciding with the null symbols of the DAB signal, the trigger is synchronized to the frame sync signal delivered by the DAB receiver. The field-strength is measured using a Rohde & Schwarz ESVB test receiver. A 3rd generation DAB receiver is used for audio moni-

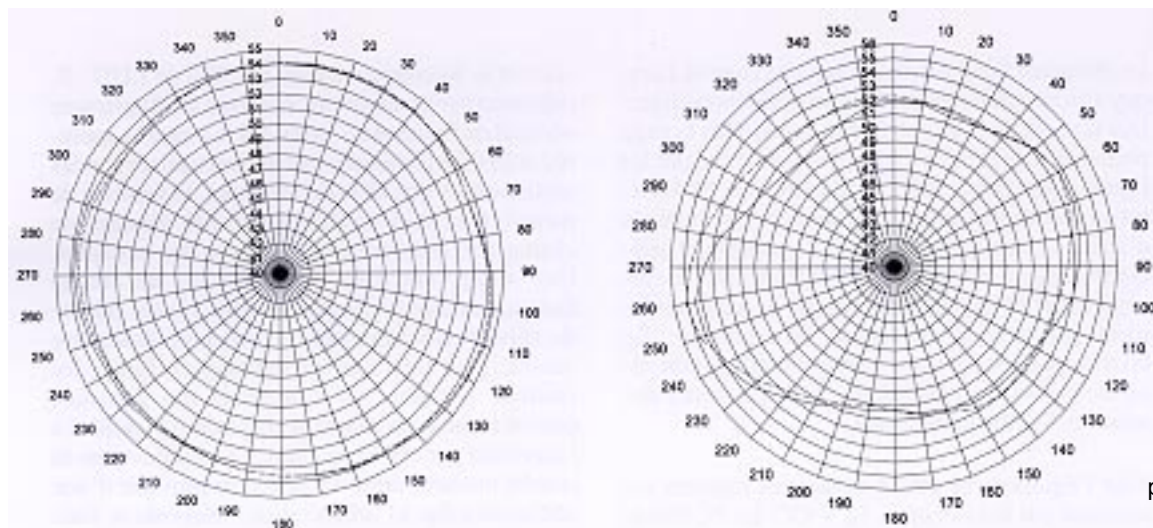

Figure 5
Horizontal polar patterns of the DAB antennas on the measurement vehicle

a) Horizontally-polarized antenna.

b) Vertically-polarized antenna.

toring and an objective indication of received quality is obtained by measuring the frequency of occurrence of the Viterbi error flag, which is evaluated by the PC. In addition, the user is able to add to the logged data an “audio error heard” marker if an audible disturbance is detected in the received signal. A Global Positioning System

(GPS) receiver sends the geographical coordinates of the vehicle to the PC once every second. The system is set up to take 200 field-strength measurements on each polarization each second (the antenna switch is operated before each successive measurement).

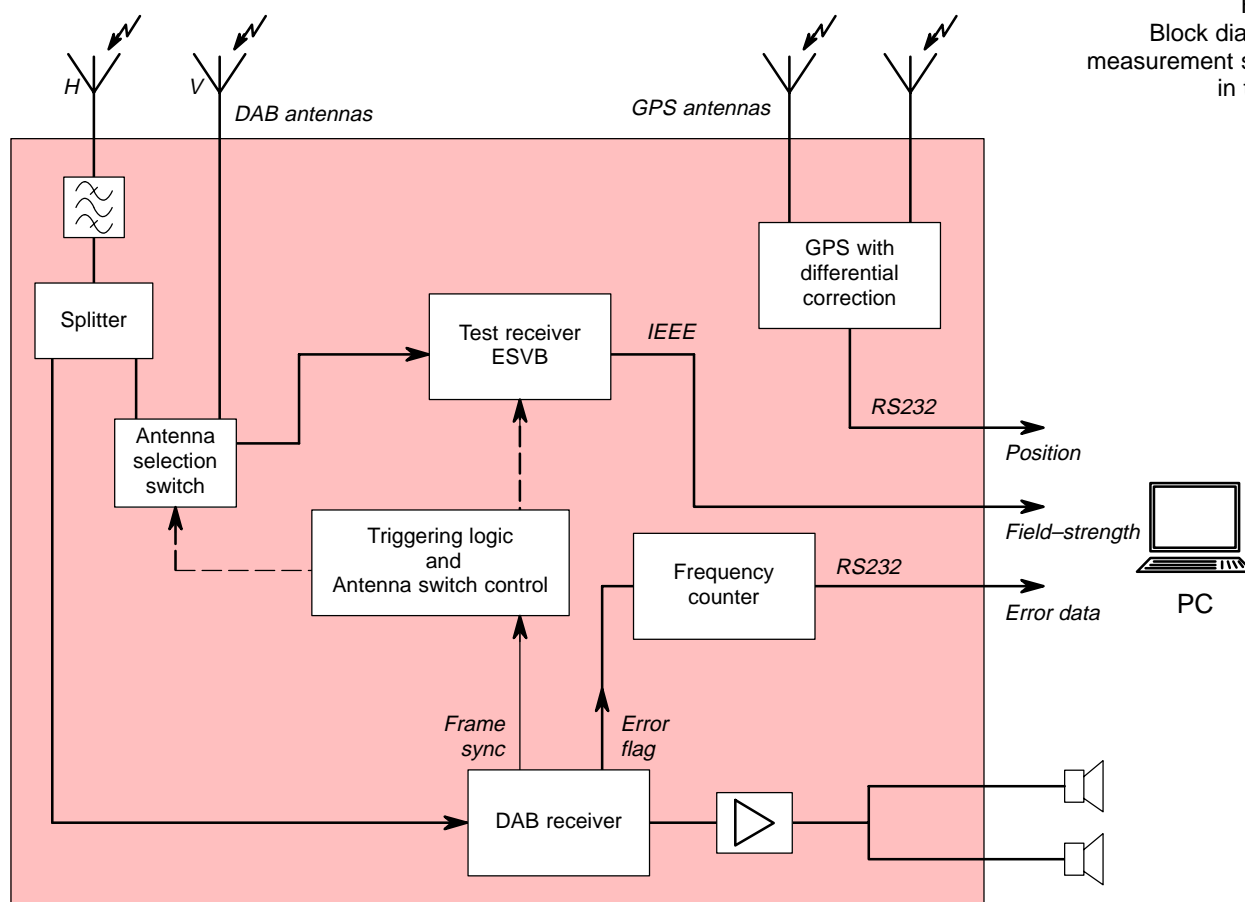

Figure 6
Block diagram of measurement systems in the van.

The 3rd generation receiver uses a wide-band television tuner at the front end and, to eliminate any unwanted signals outside the DAB frequency block, a band-pass filter is inserted between the antenna switch and the receiver.

■ 3.3. Interference

One of the potential sources of error in the measurement of DAB signals is interference generated within the test system.

The DAB receiver is mounted inside a Faraday cage to reduce problems of self-interference. Ferrite torroids and rods inside the cage are used to minimize radiation from the audio lines. The 12 V DC power cables pass through special insulators and choking coils. The headphone output and the receiver remote control connectors are not used. The receiver is mounted on a ground plane which is firmly connected to the vehicle body. The interference radiated by the electrical systems of the vehicle is sufficiently low to permit valid DAB measurements to be made.

All the equipment used during measurements is powered from the 12 V DC supply. The PC itself forms a Faraday cage and all connecting cables are filtered inside the cage using ferrite torroids. In addition, the cable of the PC keyboard passes through a 60-cm ferrite clamp.

■ 4. Preliminary results

The present article was written only shortly after the field-trial facilities had been completed and it is therefore possible only to give some preliminary results. In the results presented here, only the

field-strengths measured using the crossed-dipole antenna are considered. The frequency of the Viterbi error flag was used as a measure of DAB performance. These errors are usually audible in the receiver output when the error frequency exceeds 10 kHz.

■ 4.1. DAB coverage in Band II

Figs. 6, 7 and 8 present data measured at a radius of about 80 km from the Espoo transmitter; most of these measurements were in rural areas. In Fig. 6, the measured field-strength is plotted alongside the predicted field-strength, using the method of ITU-R Recommendation PN.370. In the prediction, no corrections have been made for the vertical pattern of the transmitting antenna. The measured curve is an average value of all the measurements taken in each 1-km section of distance travelled. More specifically, the measuring system was set up to take 200 field-strength measurements with each antenna, every second. These field-strength values were averaged over a period of 1/3 second (this is close to the interleaving time of the receiver and is therefore a good basis for statistical analysis). Finally, the values obtained in this way, for all the routes, were classified according to the distance from the transmitter, with class widths of 1 km. The deep "valley" in the measured curve at distances between 15 and 20 km is due to urban attenuation. Helsinki is 15 to 20 km away from the Espoo transmitter. In the area in which these results were obtained, the value of Δh , representing the ruggedness of the terrain, is generally less than 50 m.

Fig. 7 describes the performance of the DAB system. The amount of errors starts to rise when the distance exceeds 40 km. At greater distances the measured field-strength may fall below



Mr. Vesa Erkkilä graduated from Helsinki University of technology in 1992. He is currently working on DAB network planning and research with the Finnish Broadcasting Company. He is a member of EBU Specialist groups R1/DIG and R4/Digital, and in the SE11 Group of the CEPT.



Mr. Matti Jokisalo graduated from Helsinki University of Technology in 1993. He is working as a research engineer in the network planning service of the Finnish Broadcasting Company. He is a member of EBU Specialist Group R4/Prediction.

dBmV/m

Field-strength

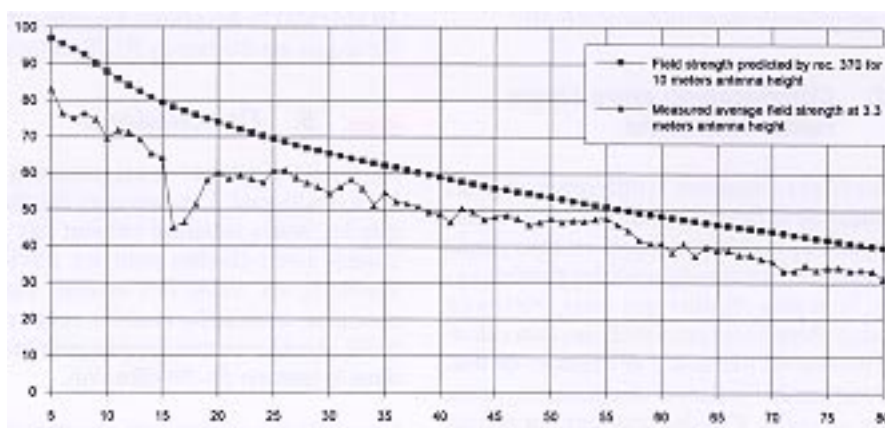

Figure 6
Comparison of measured and predicted field-strengths.

Distance from transmitter (km)

Percentage of points where error flag freq. > 10 kHz

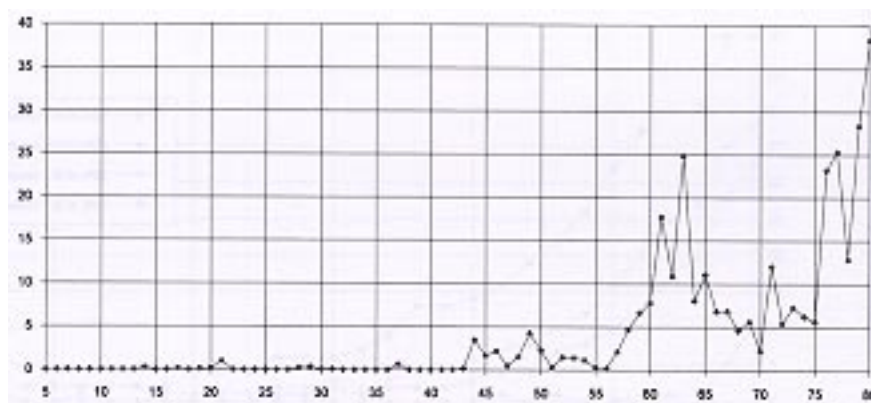

Figure 7
DAB system performance.

Distance from transmitter (km)

Std. deviation of points at specified distance

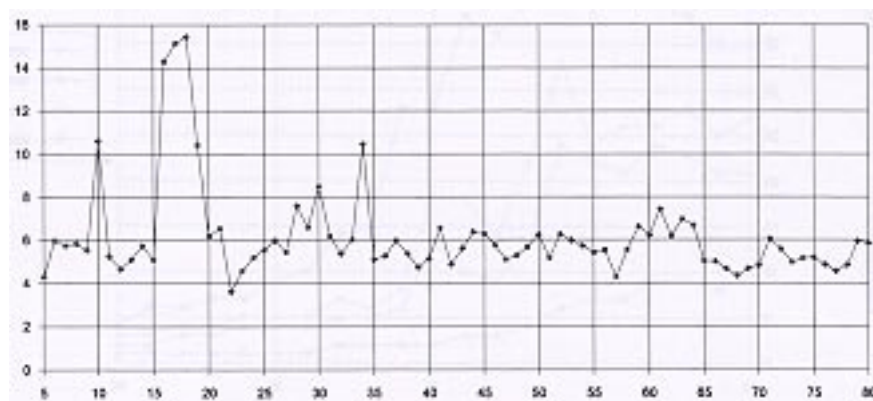

Figure 8
Standard deviation of all points measured at the specified distance from the transmitter.

Distance from transmitter (km)



50 dB μ V/m. Further study is needed to determine what constitutes “acceptable” performance in terms of measurable values such as error flag statistics. On the basis of the results so far, the coverage radius of the Espoo transmitter is some 40 to 55 km. At these distances, Recommendation ITU-R PN.370 predicts field-strengths of 59 and 51 dB μ V/m, respectively. The minimum field-strength value for planning should therefore be in this range.

Fig. 8 shows the standard deviation of all the points measured at a certain distance from the transmitter. At distances in the range from 15 to 20 km, very-high values can be seen. These are due to the large difference between the propagation loss in rural environments compared to urban areas. In the relatively flat area where the measurements were taken,

en, the standard deviation of all the measurements is generally below 6 dB.

4.2. Comparison of urban and rural environments

Figs. 9 and 10 describe the relationship between field-strength and DAB system performance in rural and urban environments, respectively. The number of rural measurements considered is quite large and the curves are quite smooth compared to those for the urban case. In these graphs, the distribution of error flag frequencies has been determined as a function of field-strength averaged over 1/3 second. From these distributions, the 50, 90, 95 and 99 percentiles have been plotted.

In the rural case (Fig. 9), a field-strength of 37 dB μ V/m must be provided in order to ensure that the error flag frequency is below 10 kHz at

Figure 9
Relationship between field-strength and DAB system performance – rural environment.

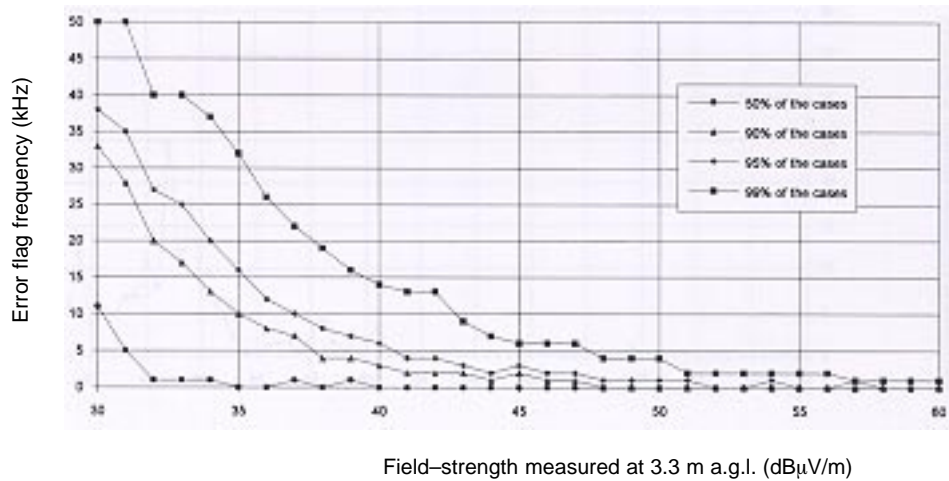
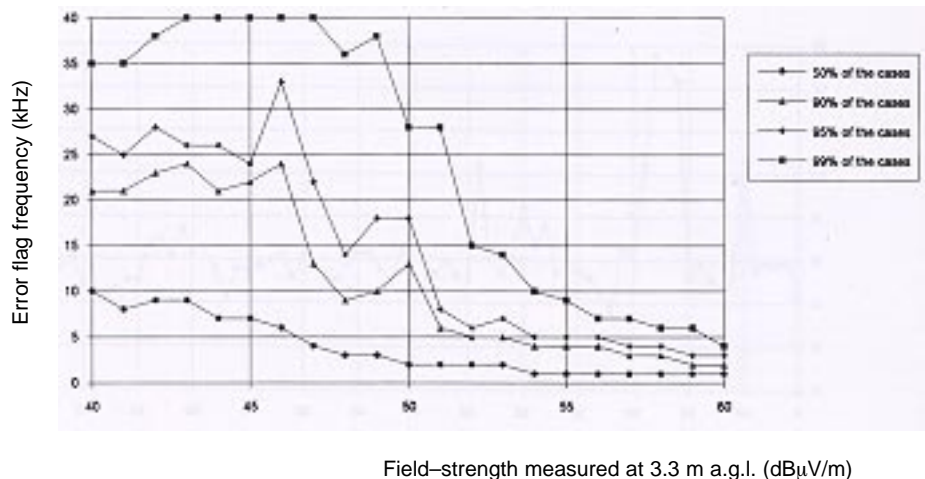

Figure 10
Relationship between field-strength and DAB system performance – urban environment.



95% of points. The corresponding value for the urban case (*Fig. 10*) is about 50 dB μ V/m.

5. Conclusions

The trial network and measuring van are working well. Quite high field-strengths are needed in dense urban areas in Band II because of the man-made noise. In rural areas a suitable minimum field-strength value for planning is expected to be in the range from 51 to 59 dB μ V/m.

The effects of losses in the splitter used to divide the received signal before the DAB and ESVB test receiver has not been studied; the DAB receiver may work correctly with lower field-strengths than the results given here suggest. On the other hand, more-detailed studies villages and small

towns may push the minimum field-strengths higher because of possible sources of man-made noise. It is not a problem to put extra transmitters in larger towns to provide a high enough field-strength to combat man-made noise levels, but it is not possible to put a transmitter into every village.

During autumn 1994, a major measurement campaign will be carried out. It is planned to compare measured field-strengths with predictions, measure protection ratios in real channels, compile field-strength statistics, and compare vertical and horizontal polarizations. Results of these measurements will be presented early in 1995.

On the basis of results so far, it may be concluded that Band II does seem to be suitable for DAB services.

1995 Conference and Exhibition Season

1995 will, for the first time, see the staging of two major broadcasting conferences, each with an accompanying exhibition and other events, in Europe in the same year.

The **19th International Television Symposium and Technical Exhibition** will take place in Montreux, Switzerland, from 8–13 June 1995. A wide-ranging Symposium programme is being arranged, covering programme production, terrestrial, satellite and cable broadcasting. Expanding on the "Future technology day" of the 1993 event, the "Future Technology Forum" will in 1995 focus on future orientations such as interactive broadcasting, flat-panel displays and virtual reality. Recognising that broadcast television is increasingly influenced by business strategies, the "Creative and Business Forum" will give participants a chance to air their views on – or learn more about – deregulation, media cross-ownership and other commercial opportunities. Catering more specifically for the needs of programme-makers, a series of Workshops will again be organized. "From tears to laughter – Television, the evocative force" is the title of the 1995 Highlight Session, illustrating the production and creative techniques by means of which television has come to touch every aspect of human emotion.

ITVS

The **International Broadcasting Convention – IBC95** will be held in Amsterdam from 14–18 September 1995. A major technical conference programme has always been a feature of IBC and for IBC95 the Conference will take on a wider remit than before to cover important issues outside the strictly technological focus of previous years. This reflects the organizers' observation that what is now central to the introduction of new technologies and services is not how they work – but rather how they are to be introduced into an increasingly commercial environment. Central to the debates will be "who wants the new services?" and "who is going to pay?". Building on previous years' experiences, IBC95 will offer panel sessions and workshops alongside the main Conference and Exhibition, with a view to serving the whole broadcast industry.

IBC95

Contact addresses for both these events will be found in the Diary on *page 88*.